

Experiment 4: DSBSC

I. OBJECTIVES

Upon completion of this experiment, you should be able to:

1. Modulate a carrier signal with a message to generate a DSBSC (double side-band suppressed carrier) signal.
2. Demodulate a DSBSC signal using a Costa's Loop.

II. INTRODUCTION

DSBSC (Double Side-band Suppressed Carrier) is a linear analog modulation technique. Given a message $m(t)$, the corresponding DSBSC signal is given by

$$s(t) = A_c \left(\frac{m(t)}{\max(|m(t)|)} \right) \cos(2\pi f_c t) = |A_c| m(t) \cos(2\pi f_c t).$$

This process is illustrated in the frequency domain as shown in Figure 1.

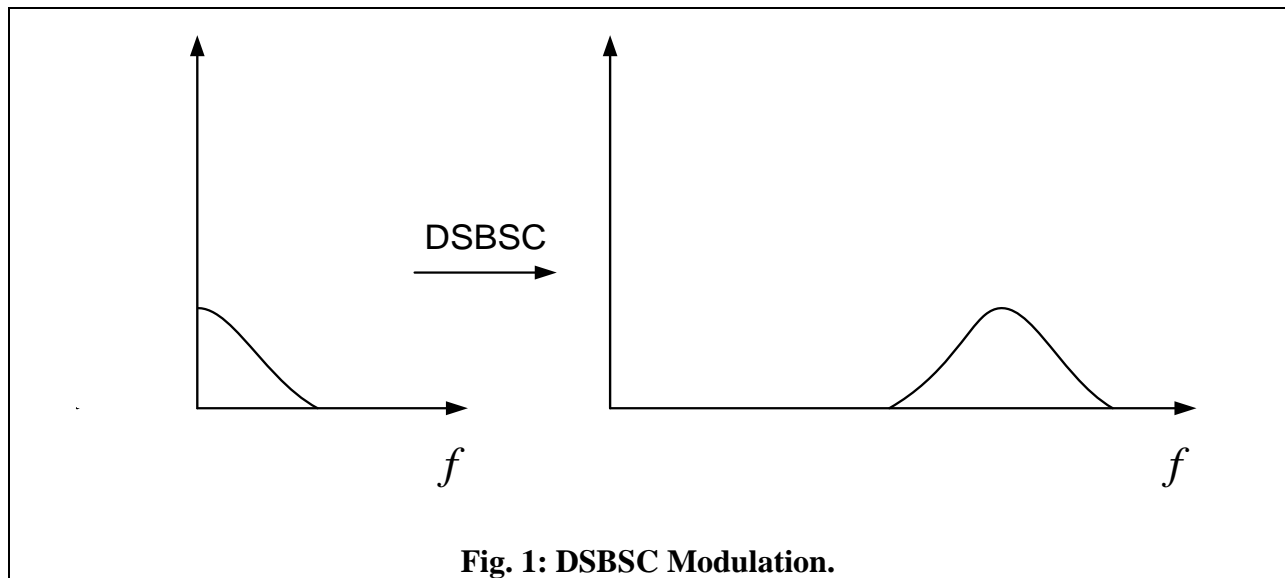

If the message is a tone, the resultant DSBSC signal will be as shown in Figure 2.

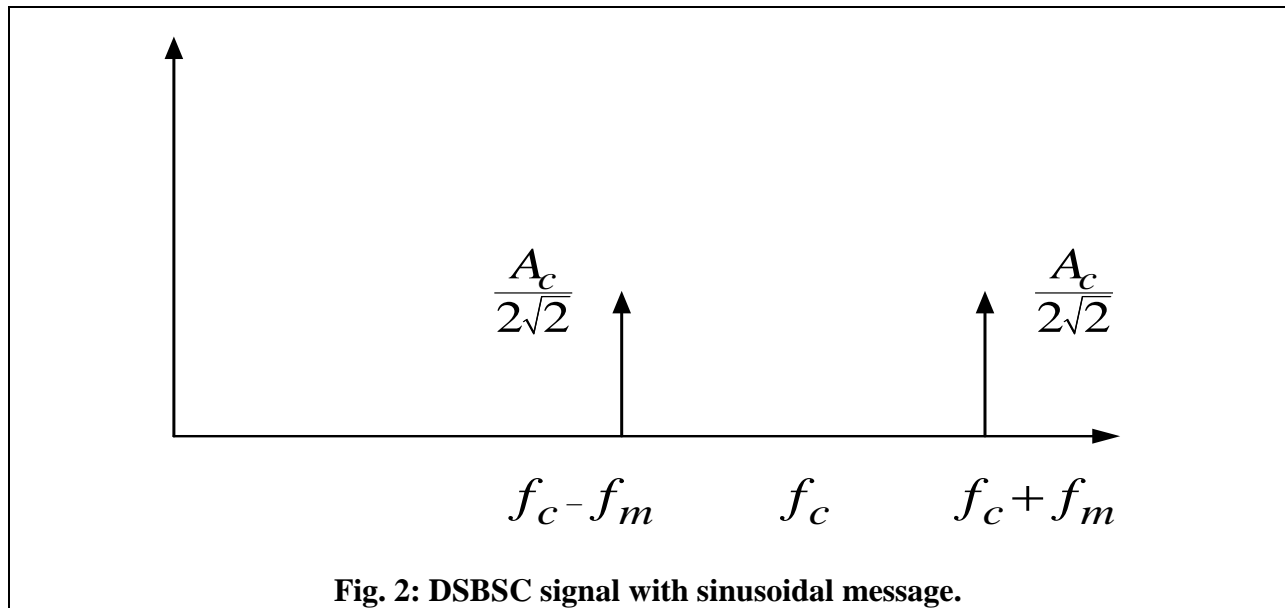

The advantage of DSBSC is that it is power-efficient since no power is wasted transmitting the carrier. Demodulation is however much more complicated than for AM since the carrier needs to be regenerated at the receiver.

Carrier regeneration can be accomplished by using techniques like Costa's loop or the squaring loop. In some cases, the carrier is not perfectly suppressed to simplify the process of carrier regeneration. Such signals can be considered to lie between perfect DSBSC and DSBL (AM). For example, stereo FM broadcast radio signals have a DSBSC signal (with a 38 kHz carrier frequency) embedded in them. A sub-harmonic of the carrier (at 19 kHz) is also embedded in the FM signal to simplify the carrier recovery; such a signal is called a pilot tone.

III. PRELAB

1. Write down a general expression for DSBSC where the carrier is $A_c \cos(2\pi f_c t)$.
2. Draw a block diagram of a synchronous detector for DSBSC.
3. Do you need a post-detector filter for synchronous detection? Why or why not?
4. Write the equations for the signals at: the input to the detector; the output of the multiplier; and the output of the filters, if you use them. Assume ideal filters.
5. What is the effect of a phase difference between the carrier and local oscillator on output quality? Consider 180° and 90° phase shifts.
6. What is the effect of a frequency difference between the carrier and local oscillator on output quality? Show mathematically.
7. Can you demodulate DSBSC using only an envelope detector? What is the result if you try? (Show equations.)
8. A Costa's loop is a type of phase-locked loop that is used to regenerate the carrier from the DSBSC signal (even though there is no component at carrier frequency present in the modulated DSBSC signal). A Costa's loop is shown in Figure 3.

Section 3.4 of the course text details phase-locked loops, particularly Costa's loop. Read about Costa's loop in your textbook and understand its operation.

Write the theoretical expression for the signals at the outputs of the two low-pass filters of the I- and Q- arms of the Costa's loop.

Write the theoretical expression for the signal at the input of the loop-filter.

Be prepared to answer quiz questions regarding the Costa's loop.

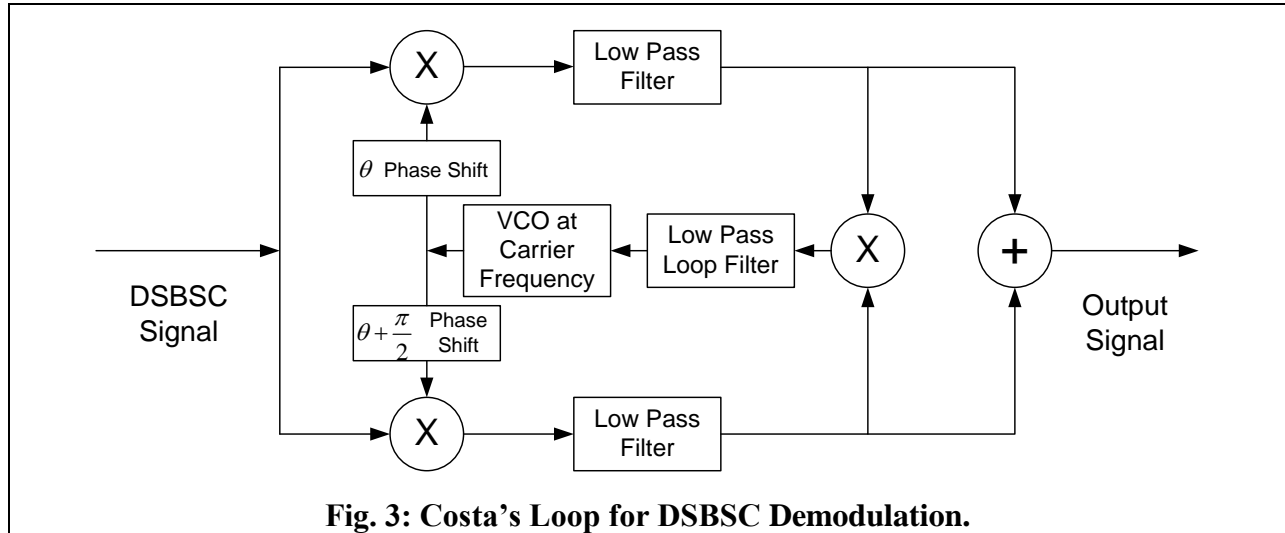

IV. EXPERIMENT

1. Generating DSBSC Signals

- 1a.** Modulate a 100 kHz carrier with a 1 kHz (symmetric) triangular message. Use the block diagram in Figure 4 as a guide.

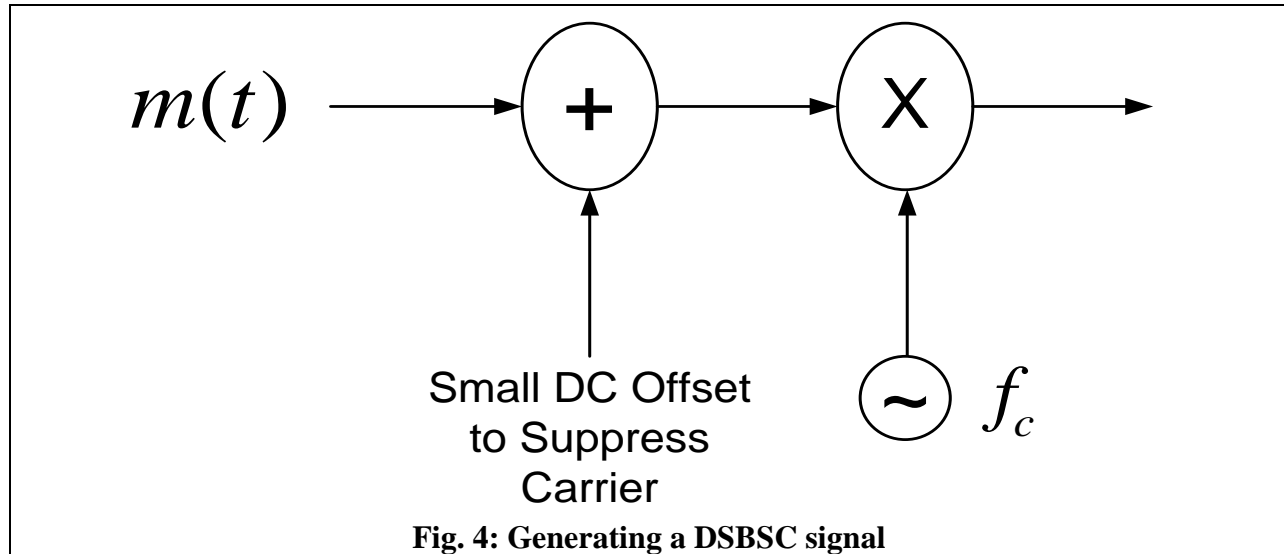

The 3314A will be used as a local oscillator later in the experiment. Use any of the other generators to generate the carrier and the message

The DC offset is merely to suppress the carrier to better account for imperfections in the multiplier. You can monitor the extent of carrier suppression using the spectrum analyzer. It should be on the order of a few millivolts. Choose the DC offset to suppress the carrier to the maximum extent possible.

- 1b.** Record your circuit and your result.
- 2. Observing Amplitude Modulated Signals.** (Figure 5)
- 2a.** Two modulated signals are shown in figure 5, below. Which of the signals is AM (with 100% modulation index) and which is DSBSC? How can you tell the difference? (Hint: same time scale, check phase reversal.)
- 2b.** For the two signals in figure 5, what is a valid message signal in each case? What is the amplitude and frequency of the message signal in each case? (Hint: they are different!)
- 2c.** Re-examine the signal generated in part 1, above. Do you see the phase reversal?

SIGNAL
1

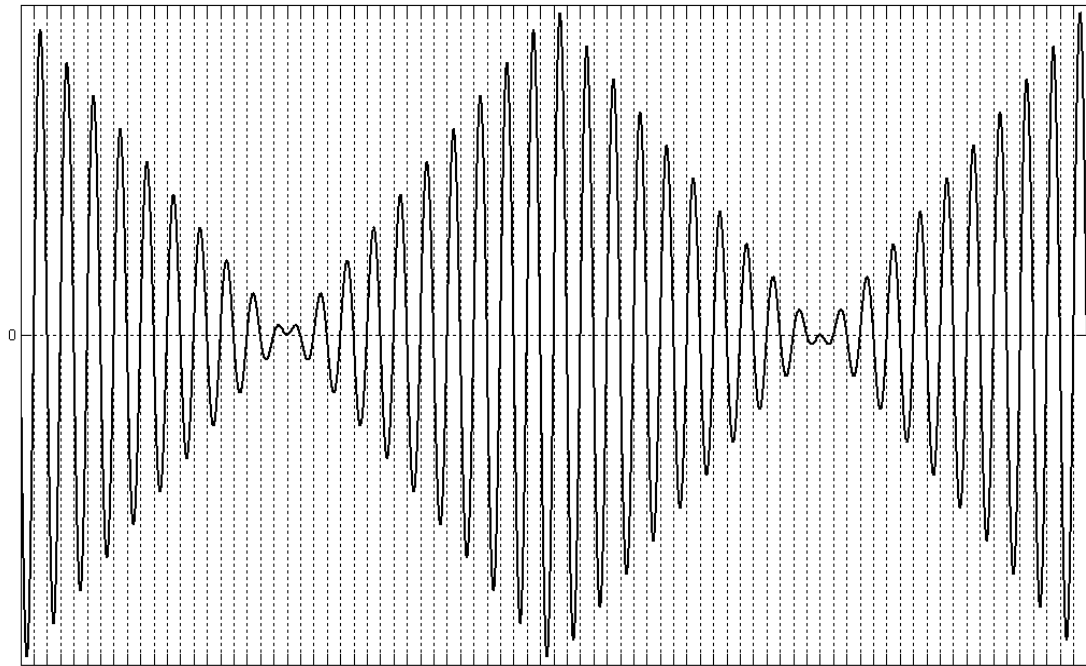

SIGNAL
2

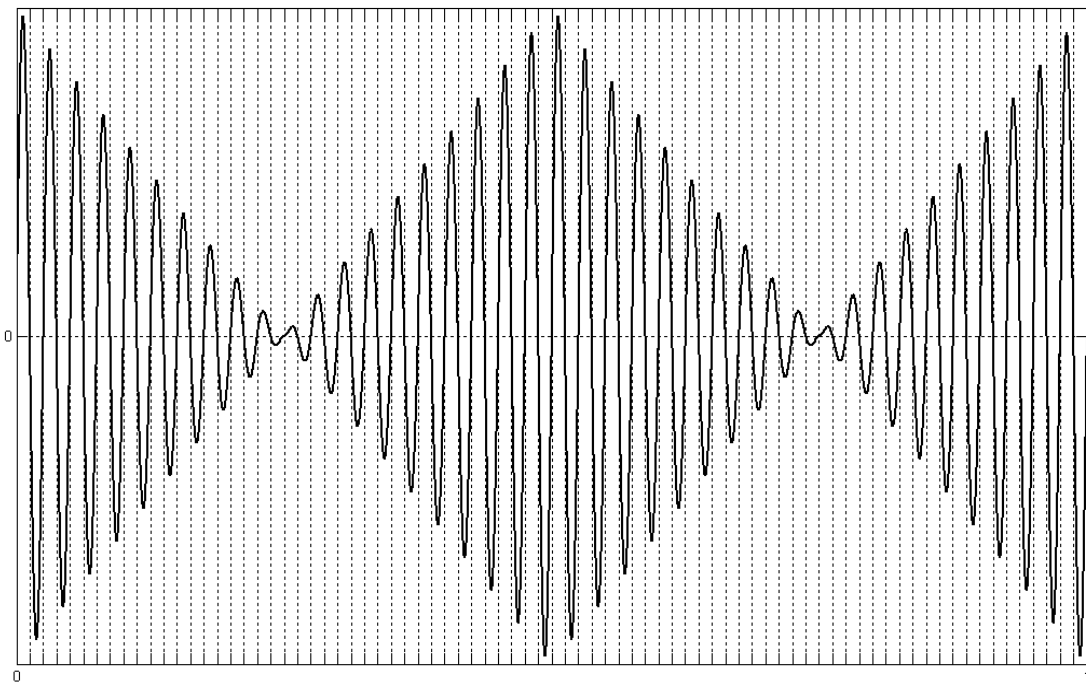

time (ms)

Fig. 5. Signals for 2a and 2b.

3. DSBSC Demodulation: Using a Stolen Carrier

To synchronously detect DSBSC, the modulated signal must be multiplied by a local oscillator at the same frequency and preferably the same phase as the carrier.

Remember that the receiver does not have a copy of the carrier available to it; it needs to generate a copy of the carrier.

3a. Stealing the Carrier.

Create a local oscillator (LO) using the 3314A;
Set the 3314A output to be a $20V_{pp}$, 100 kHz sine wave;
Connect the <SYNC> output of the generator that produces the carrier to the <TRIG> input of the 3314A;
Set the 3314A to the external trigger mode (use the <INT/EXT> button);
Press the < ϕ -lock> button;
Press the <PHASE> button and adjust the knob until the phase of the output of the 3314A matches the phase of the carrier.
(You have now officially stolen the carrier!)

3b. Build a synchronous demodulator using the stolen carrier!

Use another multiplier and the stolen carrier to demodulate the DSBSC waveform.
Don't forget the low pass filter.

3c. Determine the effect of phase difference between the actual carrier and the stolen carrier on the demodulated signal:

Use the <PHASE> button on the 3314A and determine the effect of changing the phase of the 3314A on the demodulated signal.
Compare with the theoretical result.

3d. Determine the effect of frequency difference between the carrier and local oscillator experimentally and compare to theory:

Disable the phase-lock using the <INT/EXT> button on the 3314A, then determine the effect of changing the frequency of the 3314A on the demodulated signal.
Compare with the theoretical result.

4. DSBSC Demodulation: Carrier Recovery using Costa's Loop

The Costa's loop is frequently used to recover the carrier in suppressed-carrier systems. A detailed diagram of the Costa's loop is shown below in Figure. 6.

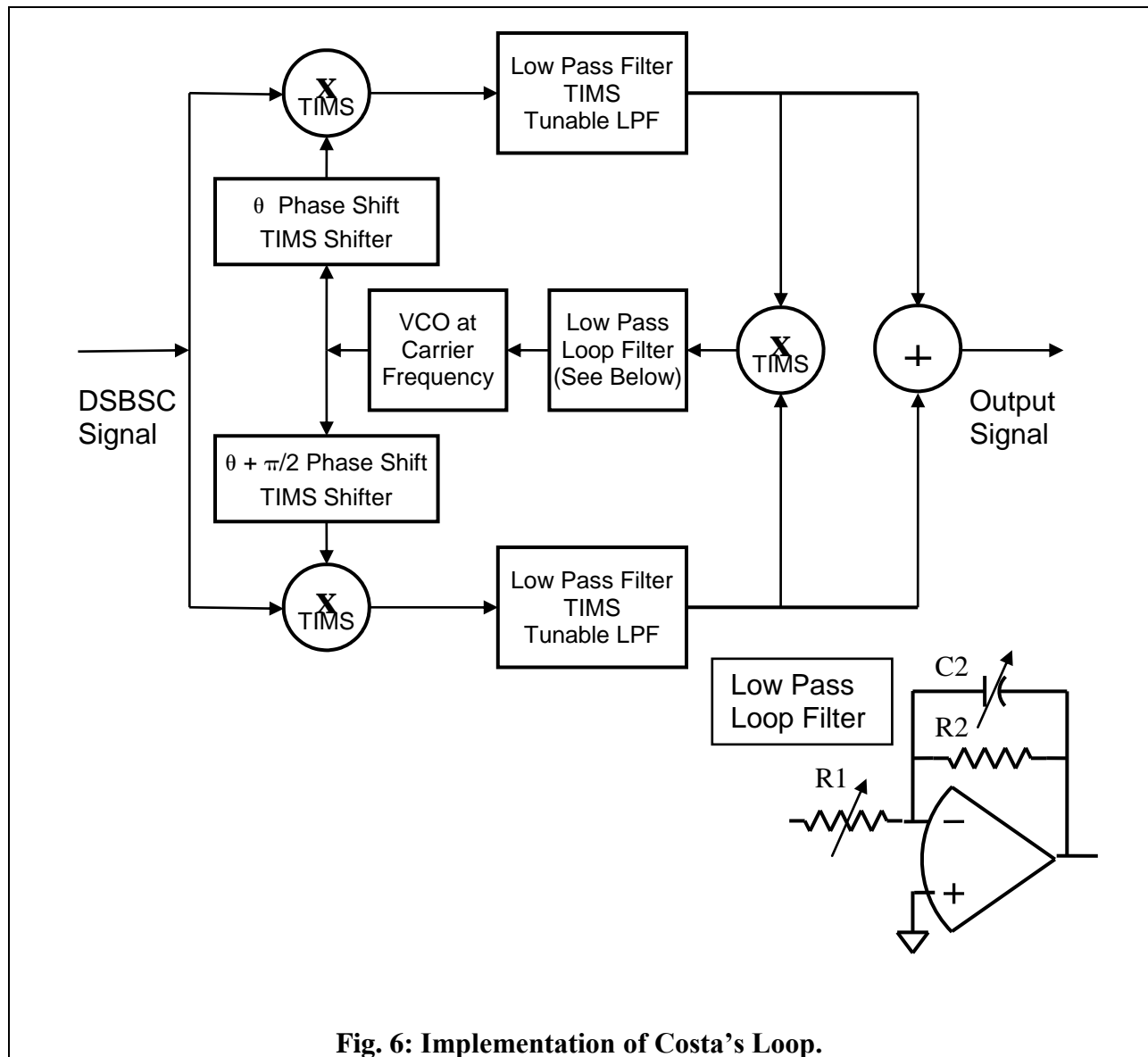

The major steps are:

- (i) Generate the DSBSC signal with a 100 kHz (20 V_{pp}) carrier. Use a 1 kHz (2 V_{pp}) triangular wave message initially. After the setup is working correctly, replace the triangular wave with music from a CD player (or other audio source).
- (ii) Set the TIMS VCO to the 'HI' mode and adjust f_0 to 100 kHz. The TIMS VCO operates at around 10 kHz in 'LO' and at around 100 kHz 'HI'.
- (iii) Ensure that the TIMS multiplier modules are configured to be DC coupled.

- (iv) Adjust the TIMS phase-shifters to produce sinusoids that are in phase quadrature (90° apart). The phase difference between the sinusoid signals can be measured using the measure feature on your oscilloscope.
- (v) Set the TIMS Tunable LPF(s) to the maximum possible bandwidth under the 'WIDE' setting.
- (vi) For the Low-pass Loop Filter, an Op-Amp Box, an adjustable resistor box for R_1 , a fixed 1 M Ω resistor for R_2 , and a decade capacitor for C_2 . are provided. Consult figure 6 for additional details.

The low-pass bandwidth of the filter is:

$$f_{3dB} = \frac{1}{2\pi R_2 C_2}.$$

The low frequency gain of the filter is:

$$A_v = -\frac{R_2}{R_1}.$$

A good starting point for R_1 and C_2 are 1 M Ω and 0.01 μ F respectively.

- (vii) Adjust the bandwidth of the loop filter by adjusting C_2 (not C_1).
 - (viii) Adjust the gain of the loop filter by adjusting R_1 .
 - (ix) Observe the output signal and the message signal on the scope to determine if the demodulator is functioning properly.
- 4a.** Build the Costa's loop and demodulate DSBSC signals corresponding to a 1 kHz triangular wave message as well as music from a CD player.

Demonstrate the functioning Costa's loop to your TA.

5. Additional Conceptual Questions Concerning Costa's Loop

Your answers to the following questions will be used to assess your understanding of the principles behind the Costas Loop. Therefore, in addition to all other questions asked in Lab 4, please answer the following in your lab report.

- 5.1** Draw a block diagram of a Costas Loop, and label all signals in the block diagram. (Tip: Express the outputs of the phase shifters as $\cos(\omega t + \theta)$ and $\sin(\omega t + \theta)$, which have the required 90 degree phase difference.)
- 5.2** Explain how the Costas Loop determines the phase error between the VCO and the carrier of the incoming DSBSC signal. (You should be able to see this in your block diagram in (5.x), with the use of some trig identities.)

- 5.2** Explain how the VCO implements negative phase feedback, i.e. how it corrects the phase error between the VCO and the incoming DSBSC carrier in order to drive the phase error to zero.

V. REPORT

Document all the readings you have obtained and any conclusions you draw in your report. Attach a copy of your lab record to the report. Answer any specific questions asked in the lab manual.

VI. APPENDIX

TIMS Modules

The TIMS modules utilize the following convention: Inputs are on the left, outputs are on the right, digital signal sockets are red, and analog signal sockets are yellow.

REFERENCES

- [1] **R. E. Ziemer and W. H. Tranter, *Principles of Communications*, 5th ed. Hoboken, NJ: John Wiley, 2002.**