

Chapter 1 Problems

Basic problems emphasize the mechanics of using concepts and methods in a manner similar to that illustrated in the examples that are solved in the text.

Advanced problems explore and elaborate upon the foundations and practical implications of the textual material.

The first section of problems belongs to the basic category, and the answers are provided in the back of the book. The next two sections contain problems belonging to the basic and advanced categories, respectively. A final section, **Mathematical Review**, provides practice problems on the fundamental ideas of complex arithmetic and algebra.

BASIC PROBLEMS WITH ANSWERS

- 1.1. Express each of the following complex numbers in Cartesian form ($x + jy$): $\frac{1}{2}e^{j\pi}$, $\frac{1}{2}e^{-j\pi}$, $e^{j\pi/2}$, $e^{-j\pi/2}$, $e^{j5\pi/2}$, $\sqrt{2}e^{j\pi/4}$, $\sqrt{2}e^{j9\pi/4}$, $\sqrt{2}e^{-j9\pi/4}$, $\sqrt{2}e^{-j\pi/4}$.
- 1.2. Express each of the following complex numbers in polar form ($re^{j\theta}$, with $-\pi < \theta \leq \pi$): 5 , -2 , $-3j$, $\frac{1}{2}$, $-j\sqrt{3}$, $1 + j$, $(1 - j)^2$, $j(1 - j)$, $(1 + j)/(1 - j)$, $(\sqrt{2} + j\sqrt{2})/(1 + j\sqrt{3})$.
- 1.3. Determine the values of P_x and E_x for each of the following signals:

(a) $x_1(t) = e^{-2t}u(t)$	(b) $x_2(t) = e^{j(2t + \pi/4)}$	(c) $x_3(t) = \cos(t)$
(d) $x_1[n] = (\frac{1}{2})^n u[n]$	(e) $x_2[n] = e^{j(\pi/2n + \pi/8)}$	(f) $x_3[n] = \cos(\frac{\pi}{4}n)$
- 1.4. Let $x[n]$ be a signal with $x[n] = 0$ for $n < -2$ and $n > 4$. For each signal given below, determine the values of n for which it is guaranteed to be zero.

(a) $x[n - 3]$	(b) $x[n + 4]$	(c) $x[-n]$
(d) $x[-n + 2]$	(e) $x[-n - 2]$	
- 1.5. Let $x(t)$ be a signal with $x(t) = 0$ for $t < 3$. For each signal given below, determine the values of t for which it is guaranteed to be zero.

(a) $x(1 - t)$	(b) $x(1 - t) + x(2 - t)$	(c) $x(1 - t)x(2 - t)$
(d) $x(3t)$	(e) $x(t/3)$	
- 1.6. Determine whether or not each of the following signals is periodic:

(a) $x_1(t) = 2e^{j(t + \pi/4)}u(t)$	(b) $x_2[n] = u[n] + u[-n]$
(c) $x_3[n] = \sum_{k=-\infty}^{\infty} \{\delta[n - 4k] - \delta[n - 1 - 4k]\}$	
- 1.7. For each signal given below, determine all the values of the independent variable at which the even part of the signal is guaranteed to be zero.

(a) $x_1[n] = u[n] - u[n - 4]$	(b) $x_2(t) = \sin(\frac{1}{2}t)$
(c) $x_3[n] = (\frac{1}{2})^n u[n - 3]$	(d) $x_4(t) = e^{-5t}u(t + 2)$
- 1.8. Express the real part of each of the following signals in the form $Ae^{-at} \cos(\omega t + \phi)$, where A , a , ω , and ϕ are real numbers with $A > 0$ and $-\pi < \phi \leq \pi$:

(a) $x_1(t) = -2$	(b) $x_2(t) = \sqrt{2}e^{j\pi/4} \cos(3t + 2\pi)$
(c) $x_3(t) = e^{-t} \sin(3t + \pi)$	(d) $x_4(t) = je^{(-2 + j100)t}$
- 1.9. Determine whether or not each of the following signals is periodic. If a signal is periodic, specify its fundamental period.

(a) $x_1(t) = je^{j10t}$	(b) $x_2(t) = e^{(-1 + j)t}$	(c) $x_3[n] = e^{j7\pi n}$
(d) $x_4[n] = 3e^{j3\pi(n + 1/2)/5}$	(e) $x_5[n] = 3e^{j3/5(n + 1/2)}$	

1.10. Determine the fundamental period of the signal $x(t) = 2 \cos(10t + 1) - \sin(4t - 1)$.

1.11. Determine the fundamental period of the signal $x[n] = 1 + e^{j4\pi n/7} - e^{j2\pi n/5}$.

1.12. Consider the discrete-time signal

$$x[n] = 1 - \sum_{k=3}^{\infty} \delta[n - 1 - k].$$

Determine the values of the integers M and n_0 so that $x[n]$ may be expressed as

$$x[n] = u[Mn - n_0].$$

1.13. Consider the continuous-time signal

$$x(t) = \delta(t + 2) - \delta(t - 2).$$

Calculate the value of E_{∞} for the signal

$$y(t) = \int_{-\infty}^t x(\tau) d\tau.$$

1.14. Consider a periodic signal

$$x(t) = \begin{cases} 1, & 0 \leq t \leq 1 \\ -2, & 1 < t < 2 \end{cases}$$

with period $T = 2$. The derivative of this signal is related to the “impulse train”

$$g(t) = \sum_{k=-\infty}^{\infty} \delta(t - 2k)$$

with period $T = 2$. It can be shown that

$$\frac{dx(t)}{dt} = A_1 g(t - t_1) + A_2 g(t - t_2).$$

Determine the values of A_1 , t_1 , A_2 , and t_2 .

1.15. Consider a system S with input $x[n]$ and output $y[n]$. This system is obtained through a series interconnection of a system S_1 followed by a system S_2 . The input-output relationships for S_1 and S_2 are

$$\begin{aligned} S_1 : \quad y_1[n] &= 2x_1[n] + 4x_1[n - 1], \\ S_2 : \quad y_2[n] &= x_2[n - 2] + \frac{1}{2}x_2[n - 3], \end{aligned}$$

where $x_1[n]$ and $x_2[n]$ denote input signals.

(a) Determine the input-output relationship for system S .

(b) Does the input-output relationship of system S change if the order in which S_1 and S_2 are connected in series is reversed (i.e., if S_2 follows S_1)?

1.16. Consider a discrete-time system with input $x[n]$ and output $y[n]$. The input-output relationship for this system is

$$y[n] = x[n]x[n - 2].$$

- (a) Is the system memoryless?
- (b) Determine the output of the system when the input is $A\delta[n]$, where A is any real or complex number.
- (c) Is the system invertible?

1.17. Consider a continuous-time system with input $x(t)$ and output $y(t)$ related by

$$y(t) = x(\sin(t)).$$

- (a) Is this system causal?
- (b) Is this system linear?

1.18. Consider a discrete-time system with input $x[n]$ and output $y[n]$ related by

$$y[n] = \sum_{k=n-n_0}^{n+n_0} x[k],$$

where n_0 is a finite positive integer.

- (a) Is this system linear?
- (a) Is this system time-invariant?
- (c) If $x[n]$ is known to be bounded by a finite integer B (i.e., $|x[n]| < B$ for all n), it can be shown that $y[n]$ is bounded by a finite number C . We conclude that the given system is stable. Express C in terms of B and n_0 .

1.19. For each of the following input-output relationships, determine whether the corresponding system is linear, time invariant or both.

- (a) $y(t) = t^2 x(t - 1)$
- (b) $y[n] = x^2[n - 2]$
- (c) $y[n] = x[n + 1] - x[n - 1]$
- (d) $y[n] = \mathcal{O}\mathcal{D}\{x(t)\}$

1.20. A continuous-time linear system S with input $x(t)$ and output $y(t)$ yields the following input-output pairs:

$$x(t) = e^{j2t} \xrightarrow{S} y(t) = e^{j3t},$$

$$x(t) = e^{-j2t} \xrightarrow{S} y(t) = e^{-j3t}.$$

- (a) If $x_1(t) = \cos(2t)$, determine the corresponding output $y_1(t)$ for system S .
- (b) If $x_2(t) = \cos(2(t - \frac{1}{2}))$, determine the corresponding output $y_2(t)$ for system S .

BASIC PROBLEMS

1.21. A continuous-time signal $x(t)$ is shown in Figure P1.21. Sketch and label carefully each of the following signals:

- (a) $x(t - 1)$
- (b) $x(2 - t)$
- (c) $x(2t + 1)$
- (d) $x(4 - \frac{t}{2})$
- (e) $[x(t) + x(-t)]u(t)$
- (f) $x(t)[\delta(t + \frac{3}{2}) - \delta(t - \frac{3}{2})]$

1.22. A discrete-time signal is shown in Figure P1.22. Sketch and label carefully each of the following signals:

- (a) $x[n - 4]$
- (b) $x[3 - n]$
- (c) $x[3n]$
- (d) $x[3n + 1]$
- (e) $x[n]u[3 - n]$
- (f) $x[n - 2]\delta[n - 2]$
- (g) $\frac{1}{2}x[n] + \frac{1}{2}(-1)^n x[n]$
- (h) $x[(n - 1)^2]$

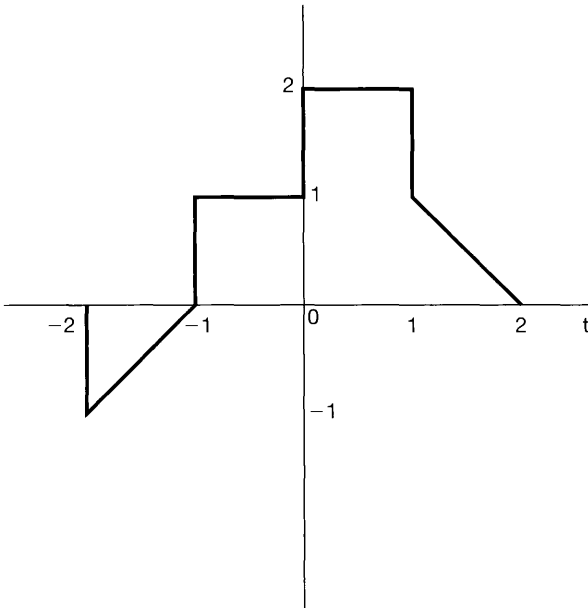

Figure P1.21

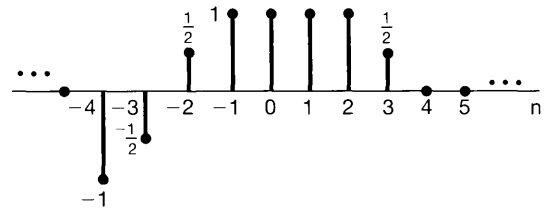

Figure P1.22

1.23. Determine and sketch the even and odd parts of the signals depicted in Figure P1.23. Label your sketches carefully.

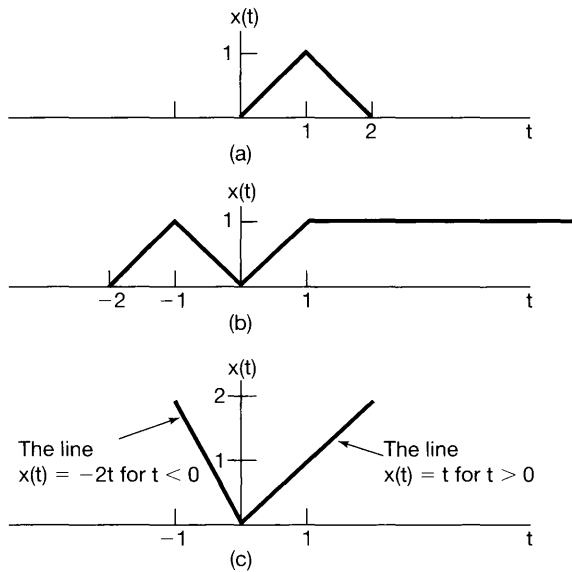

Figure P1.23

1.24. Determine and sketch the even and odd parts of the signals depicted in Figure P1.24. Label your sketches carefully.

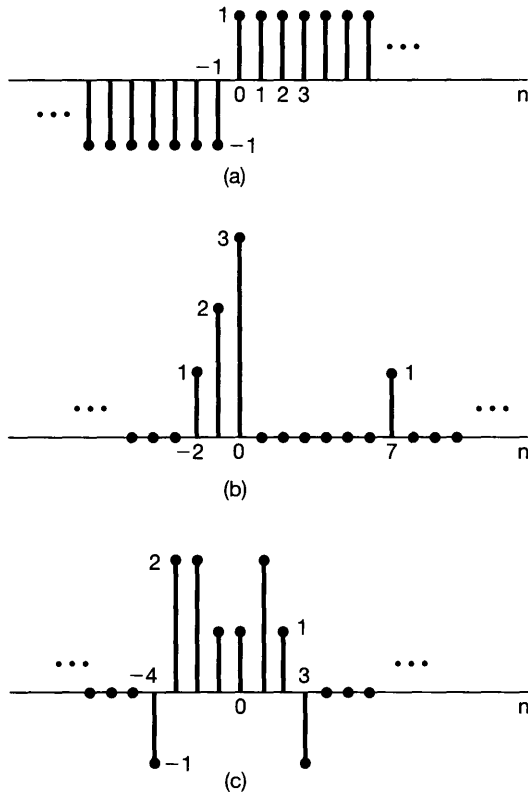

Figure P1.24

1.25. Determine whether or not each of the following continuous-time signals is periodic.

If the signal is periodic, determine its fundamental period.

(a) $x(t) = 3 \cos(4t + \frac{\pi}{3})$ (b) $x(t) = e^{j(\pi t - 1)}$
 (c) $x(t) = [\cos(2t - \frac{\pi}{3})]^2$ (d) $x(t) = \mathcal{E}\nu\{\cos(4\pi t)u(t)\}$

(e) $x(t) = \mathcal{E}\nu\{\sin(4\pi t)u(t)\}$ (f) $x(t) = \sum_{n=-\infty}^{\infty} e^{-(2t-n)}u(2t-n)$

1.26. Determine whether or not each of the following discrete-time signals is periodic. If the signal is periodic, determine its fundamental period.

(a) $x[n] = \sin(\frac{6\pi}{7}n + 1)$ (b) $x[n] = \cos(\frac{n}{8} - \pi)$ (c) $x[n] = \cos(\frac{\pi}{8}n^2)$
 (d) $x[n] = \cos(\frac{\pi}{2}n)\cos(\frac{\pi}{4}n)$ (e) $x[n] = 2 \cos(\frac{\pi}{4}n) + \sin(\frac{\pi}{8}n) - 2 \cos(\frac{\pi}{2}n + \frac{\pi}{6})$

1.27. In this chapter, we introduced a number of general properties of systems. In particular, a system may or may not be

- (1) Memoryless
- (2) Time invariant
- (3) Linear
- (4) Causal
- (5) Stable

Determine which of these properties hold and which do not hold for each of the following continuous-time systems. Justify your answers. In each example, $y(t)$ denotes the system output and $x(t)$ is the system input.

$$\begin{array}{ll}
 \text{(a)} \quad y(t) = x(t-2) + x(2-t) & \text{(b)} \quad y(t) = [\cos(3t)]x(t) \\
 \text{(c)} \quad y(t) = \int_{-\infty}^{2t} x(\tau)d\tau & \text{(d)} \quad y(t) = \begin{cases} 0, & t < 0 \\ x(t) + x(t-2), & t \geq 0 \end{cases} \\
 \text{(e)} \quad y(t) = \begin{cases} 0, & x(t) < 0 \\ x(t) + x(t-2), & x(t) \geq 0 \end{cases} & \text{(f)} \quad y(t) = x(t/3) \\
 \text{(g)} \quad y(t) = \frac{dx(t)}{dt}
 \end{array}$$

1.28. Determine which of the properties listed in Problem 1.27 hold and which do not hold for each of the following discrete-time systems. Justify your answers. In each example, $y[n]$ denotes the system output and $x[n]$ is the system input.

$$\begin{array}{ll}
 \text{(a)} \quad y[n] = x[-n] & \text{(b)} \quad y[n] = x[n-2] - 2x[n-8] \\
 \text{(c)} \quad y[n] = nx[n] & \text{(d)} \quad y[n] = \mathcal{E}_v\{x[n-1]\} \\
 \text{(e)} \quad y[n] = \begin{cases} x[n], & n \geq 1 \\ 0, & n = 0 \\ x[n+1], & n \leq -1 \end{cases} & \text{(f)} \quad y[n] = \begin{cases} x[n], & n \geq 1 \\ 0, & n = 0 \\ x[n], & n \leq -1 \end{cases} \\
 \text{(g)} \quad y[n] = x[4n+1]
 \end{array}$$

1.29. (a) Show that the discrete-time system whose input $x[n]$ and output $y[n]$ are related by $y[n] = \Re\{x[n]\}$ is additive. Does this system remain additive if its input-output relationship is changed to $y[n] = \Re\{e^{j\pi n/4}x[n]\}$? (Do not assume that $x[n]$ is real in this problem.)

(b) In the text, we discussed the fact that the property of linearity for a system is equivalent to the system possessing both the additivity property and homogeneity property. Determine whether each of the systems defined below is additive and/or homogeneous. Justify your answers by providing a proof for each property if it holds or a counterexample if it does not.

$$\text{(i)} \quad y(t) = \frac{1}{x(t)} \left[\frac{dx(t)}{dt} \right]^2 \quad \text{(ii)} \quad y[n] = \begin{cases} \frac{x[n]x[n-2]}{x[n-1]}, & x[n-1] \neq 0 \\ 0, & x[n-1] = 0 \end{cases}$$

1.30. Determine if each of the following systems is invertible. If it is, construct the inverse system. If it is not, find two input signals to the system that have the same output.

$$\begin{array}{ll}
 \text{(a)} \quad y(t) = x(t-4) & \text{(b)} \quad y(t) = \cos[x(t)] \\
 \text{(c)} \quad y[n] = nx[n] & \text{(d)} \quad y(t) = \int_{-\infty}^t x(\tau)d\tau \\
 \text{(e)} \quad y[n] = \begin{cases} x[n-1], & n \geq 1 \\ 0, & n = 0 \\ x[n], & n \leq -1 \end{cases} & \text{(f)} \quad y[n] = x[n]x[n-1] \\
 \text{(g)} \quad y[n] = x[1-n] & \text{(h)} \quad y(t) = \int_{-\infty}^t e^{-(t-\tau)}x(\tau)d\tau \\
 \text{(i)} \quad y[n] = \sum_{k=-\infty}^n \left(\frac{1}{2}\right)^{n-k}x[k] & \text{(j)} \quad y(t) = \frac{dx(t)}{dt} \\
 \text{(k)} \quad y[n] = \begin{cases} x[n+1], & n \geq 0 \\ x[n], & n \leq -1 \end{cases} & \text{(l)} \quad y(t) = x(2t)
 \end{array}$$

$$\text{(m)} \quad y[n] = x[2n] \quad \text{(n)} \quad y[n] = \begin{cases} x[n/2], & n \text{ even} \\ 0, & n \text{ odd} \end{cases}$$

1.31. In this problem, we illustrate one of the most important consequences of the properties of linearity and time invariance. Specifically, once we know the response of a linear system or a linear time-invariant (LTI) system to a single input or the responses to several inputs, we can directly compute the responses to many other

input signals. Much of the remainder of this book deals with a thorough exploitation of this fact in order to develop results and techniques for analyzing and synthesizing LTI systems.

- (a) Consider an LTI system whose response to the signal $x_1(t)$ in Figure P1.31(a) is the signal $y_1(t)$ illustrated in Figure P1.31(b). Determine and sketch carefully the response of the system to the input $x_2(t)$ depicted in Figure P1.31(c).
- (b) Determine and sketch the response of the system considered in part (a) to the input $x_3(t)$ shown in Figure P1.31(d).

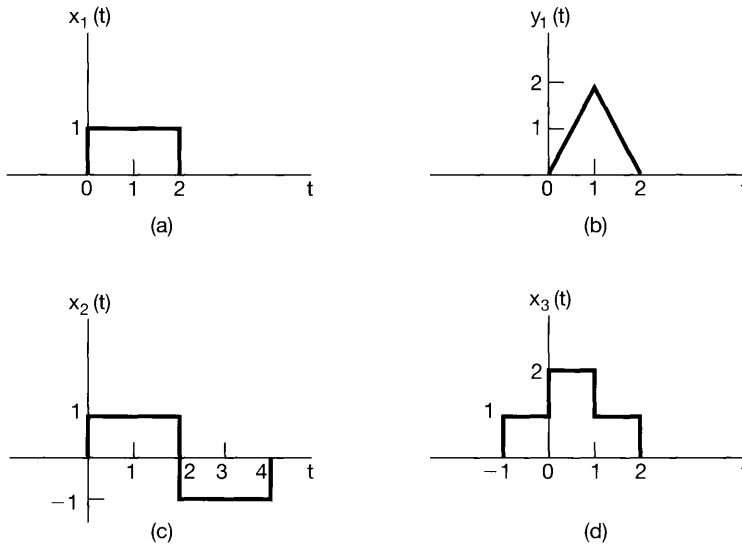

Figure P1.31

ADVANCED PROBLEMS

- 1.32. Let $x(t)$ be a continuous-time signal, and let

$$y_1(t) = x(2t) \text{ and } y_2(t) = x(t/2).$$

The signal $y_1(t)$ represents a speeded up version of $x(t)$ in the sense that the duration of the signal is cut in half. Similarly, $y_2(t)$ represents a slowed down version of $x(t)$ in the sense that the duration of the signal is doubled. Consider the following statements:

- (1) If $x(t)$ is periodic, then $y_1(t)$ is periodic.
- (2) If $y_1(t)$ is periodic, then $x(t)$ is periodic.
- (3) If $x(t)$ is periodic, then $y_2(t)$ is periodic.
- (4) If $y_2(t)$ is periodic, then $x(t)$ is periodic.

For each of these statements, determine whether it is true, and if so, determine the relationship between the fundamental periods of the two signals considered in the statement. If the statement is not true, produce a counterexample to it.

- 1.33. Let $x[n]$ be a discrete-time signal, and let

$$y_1[n] = x[2n] \text{ and } y_2[n] = \begin{cases} x[n/2], & n \text{ even} \\ 0, & n \text{ odd} \end{cases}$$

The signals $y_1[n]$ and $y_2[n]$ respectively represent in some sense the speeded up and slowed down versions of $x[n]$. However, it should be noted that the discrete-time notions of speeded up and slowed down have subtle differences with respect to their continuous-time counterparts. Consider the following statements:

- (1) If $x[n]$ is periodic, then $y_1[n]$ is periodic.
- (2) If $y_1[n]$ is periodic, then $x[n]$ is periodic.
- (3) If $x[n]$ is periodic, then $y_2[n]$ is periodic.
- (4) If $y_2[n]$ is periodic, then $x[n]$ is periodic.

For each of these statements, determine whether it is true, and if so, determine the relationship between the fundamental periods of the two signals considered in the statement. If the statement is not true, produce a counterexample to it.

1.34. In this problem, we explore several of the properties of even and odd signals.

- (a) Show that if $x[n]$ is an odd signal, then

$$\sum_{n=-\infty}^{+\infty} x[n] = 0.$$

- (b) Show that if $x_1[n]$ is an odd signal and $x_2[n]$ is an even signal, then $x_1[n]x_2[n]$ is an odd signal.

- (c) Let $x[n]$ be an arbitrary signal with even and odd parts denoted by

$$x_e[n] = \mathcal{E}\{x[n]\}$$

and

$$x_o[n] = \mathcal{O}\{x[n]\}.$$

Show that

$$\sum_{n=-\infty}^{+\infty} x^2[n] = \sum_{n=-\infty}^{+\infty} x_e^2[n] + \sum_{n=-\infty}^{+\infty} x_o^2[n].$$

- (d) Although parts (a)–(c) have been stated in terms of discrete-time signals, the analogous properties are also valid in continuous time. To demonstrate this, show that

$$\int_{-\infty}^{+\infty} x^2(t)dt = \int_{-\infty}^{+\infty} x_e^2(t)dt + \int_{-\infty}^{+\infty} x_o^2(t)dt,$$

where $x_e(t)$ and $x_o(t)$ are, respectively, the even and odd parts of $x(t)$.

1.35. Consider the periodic discrete-time exponential time signal

$$x[n] = e^{jm(2\pi/N)n}.$$

Show that the fundamental period of this signal is

$$N_0 = N/\text{gcd}(m, N),$$

where $\text{gcd}(m, N)$ is the *greatest common divisor* of m and N —that is, the largest integer that divides both m and N an integral number of times. For example,

$$\text{gcd}(2, 3) = 1, \text{gcd}(2, 4) = 2, \text{gcd}(8, 12) = 4.$$

Note that $N_0 = N$ if m and N have no factors in common.

1.36. Let $x(t)$ be the continuous-time complex exponential signal

$$x(t) = e^{j\omega_0 t}$$

with fundamental frequency ω_0 and fundamental period $T_0 = 2\pi/\omega_0$. Consider the discrete-time signal obtained by taking equally spaced samples of $x(t)$ —that is,

$$x[n] = x(nT) = e^{j\omega_0 nT}.$$

- (a) Show that $x[n]$ is periodic if and only if T/T_0 is a rational number—that is, if and only if some multiple of the sampling interval *exactly equals* a multiple of the period of $x(t)$.
- (b) Suppose that $x[n]$ is periodic—that is, that

$$\frac{T}{T_0} = \frac{p}{q}, \quad (\text{P1.36-1})$$

where p and q are integers. What are the fundamental period and fundamental frequency of $x[n]$? Express the fundamental frequency as a fraction of $\omega_0 T$.

- (c) Again assuming that T/T_0 satisfies eq. (P1.36-1), determine precisely how many periods of $x(t)$ are needed to obtain the samples that form a single period of $x[n]$.

1.37. An important concept in many communications applications is the *correlation* between two signals. In the problems at the end of Chapter 2, we will have more to say about this topic and will provide some indication of how it is used in practice. For now, we content ourselves with a brief introduction to correlation functions and some of their properties.

Let $x(t)$ and $y(t)$ be two signals; then the *correlation function* is defined as

$$\phi_{xy}(t) = \int_{-\infty}^{\infty} x(t + \tau)y(\tau)d\tau.$$

The function $\phi_{xx}(t)$ is usually referred to as the *autocorrelation function* of the signal $x(t)$, while $\phi_{xy}(t)$ is often called a *cross-correlation function*.

- (a) What is the relationship between $\phi_{xy}(t)$ and $\phi_{yx}(t)$?
- (b) Compute the odd part of $\phi_{xx}(t)$.
- (c) Suppose that $y(t) = x(t + T)$. Express $\phi_{xy}(t)$ and $\phi_{yy}(t)$ in terms of $\phi_{xx}(t)$.
- 1.38.** In this problem, we examine a few of the properties of the unit impulse function.
- (a) Show that

$$\delta(2t) = \frac{1}{2}\delta(t).$$

Hint: Examine $\delta_{\Delta}(t)$. (See Figure 1.34.)

- (b) In Section 1.4, we defined the continuous-time unit impulse as the limit of the signal $\delta_{\Delta}(t)$. More precisely, we defined several of the *properties* of $\delta(t)$ by examining the corresponding properties of $\delta_{\Delta}(t)$. For example, since the signal

$$u_{\Delta}(t) = \int_{-\infty}^t \delta_{\Delta}(\tau)d\tau$$

converges to the unit step

$$u(t) = \lim_{\Delta \rightarrow 0} u_{\Delta}(t), \quad (\text{P1.38-1})$$

we could interpret $\delta(t)$ through the equation

$$u(t) = \int_{-\infty}^t \delta(\tau) d\tau$$

or by viewing $\delta(t)$ as the formal derivative of $u(t)$.

This type of discussion is important, as we are in effect trying to define $\delta(t)$ through its properties rather than by specifying its value for each t , which is not possible. In Chapter 2, we provide a very simple characterization of the behavior of the unit impulse that is extremely useful in the study of linear time-invariant systems. For the present, however, we concentrate on demonstrating that the important concept in using the unit impulse is to understand *how* it behaves. To do this, consider the six signals depicted in Figure P1.38. Show

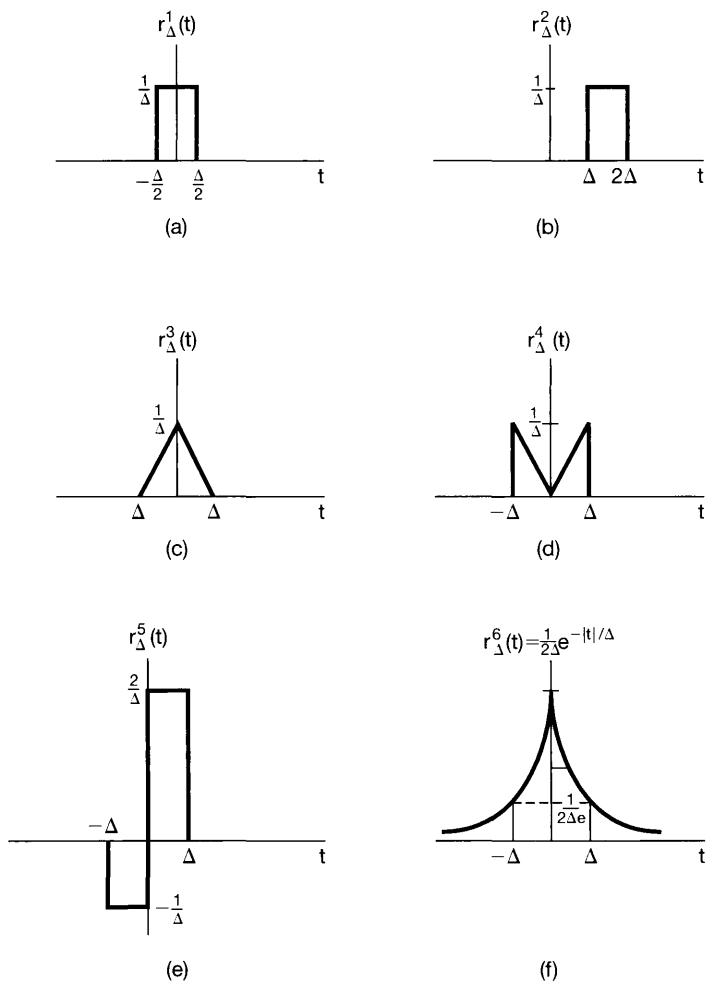

Figure P1.38

that each “behaves like an impulse” as $\Delta \rightarrow 0$ in that, if we let

$$u_{\Delta}^i(t) = \int_{-\infty}^t r_{\Delta}^i(\tau) d\tau,$$

then

$$\lim_{\Delta \rightarrow 0} u_{\Delta}^i(t) = u(t).$$

In each case, sketch and label carefully the signal $u_{\Delta}^i(t)$. Note that

$$r_{\Delta}^2(0) = r_{\Delta}^4(0) = 0 \text{ for all } \Delta.$$

Therefore, it is not enough to define or to think of $\delta(t)$ as being zero for $t \neq 0$ and infinite for $t = 0$. Rather, it is properties such as eq. (P1.38–1) that define the impulse. In Section 2.5 we will define a whole class of signals known as *singularity functions*, which are related to the unit impulse and which are also defined in terms of their properties rather than their values.

- 1.39.** The role played by $u(t)$, $\delta(t)$, and other singularity functions in the study of linear time-invariant systems is that of an *idealization* of a physical phenomenon, and, as we will see, the use of these idealizations allow us to obtain an exceedingly important and very simple representation of such systems. In using singularity functions, we need, however, to be careful. In particular, we must remember that they are idealizations, and thus, whenever we perform a calculation using them, we are implicitly assuming that this calculation represents an accurate description of the behavior of the signals that they are intended to idealize. To illustrate, consider the equation

$$x(t)\delta(t) = x(0)\delta(t). \quad (\text{P1.39–1})$$

This equation is based on the observation that

$$x(t)\delta_{\Delta}(t) \approx x(0)\delta_{\Delta}(t). \quad (\text{P1.39–2})$$

Taking the limit of this relationship then yields the idealized one given by eq. (P1.39–1). However, a more careful examination of our derivation of eq. (P1.39–2) shows that that equation really makes sense only if $x(t)$ is continuous at $t = 0$. If it is not, then we will not have $x(t) \approx x(0)$ for t small.

To make this point clearer, consider the unit step signal $u(t)$. Recall from eq. (1.70) that $u(t) = 0$ for $t < 0$ and $u(t) = 1$ for $t > 0$, but that its value at $t = 0$ is not defined. [Note, for example, that $u_{\Delta}(0) = 0$ for all Δ , while $u_{\Delta}^1(0) = \frac{1}{2}$ (from Problem 1.38(b)).] The fact that $u(0)$ is not defined is not particularly bothersome, as long as the calculations we perform using $u(t)$ do not rely on a specific choice for $u(0)$. For example, if $f(t)$ is a signal that is continuous at $t = 0$, then the value of

$$\int_{-\infty}^{+\infty} f(\sigma)u(\sigma)d\sigma$$

does not depend upon a choice for $u(0)$. On the other hand, the fact that $u(0)$ is undefined is significant in that it means that certain calculations involving singularity functions are undefined. Consider trying to define a value for the product $u(t)\delta(t)$.

To see that this *cannot* be defined, show that

$$\lim_{\Delta \rightarrow 0} [u_{\Delta}(t)\delta(t)] = 0,$$

but

$$\lim_{\Delta \rightarrow 0} [u_{\Delta}(t)\delta_{\Delta}(t)] = \frac{1}{2}\delta(t).$$

In general, we can define the product of two signals without any difficulty, as long as the signals do not contain singularities (discontinuities, impulses, or the other singularities introduced in Section 2.5) whose locations coincide. When the locations do coincide, the product is undefined. As an example, show that the signal

$$g(t) = \int_{-\infty}^{+\infty} u(\tau)\delta(t - \tau)d\tau$$

is identical to $u(t)$; that is, it is 0 for $t < 0$, it equals 1 for $t > 0$, and it is undefined for $t = 0$.

- 1.40.** (a) Show that if a system is *either* additive or homogeneous, it has the property that if the input is identically zero, then the output is also identically zero.
 (b) Determine a system (either in continuous or discrete time) that is *neither* additive *nor* homogeneous but which has a zero output if the input is identically zero.
 (c) From part (a), can you conclude that if the input to a linear system is zero between times t_1 and t_2 in continuous time or between times n_1 and n_2 in discrete time, then its output must also be zero between these same times? Explain your answer.

- 1.41.** Consider a system S with input $x[n]$ and output $y[n]$ related by

$$y[n] = x[n]\{g[n] + g[n - 1]\}.$$

- (a) If $g[n] = 1$ for all n , show that S is time invariant.
 (b) If $g[n] = n$, show that S is not time invariant.
 (c) If $g[n] = 1 + (-1)^n$, show that S is time invariant.
- 1.42.** (a) Is the following statement true or false?

The series interconnection of two linear time-invariant systems is itself a linear, time-invariant system.

Justify your answer.

- (b) Is the following statement true or false?

The series interconnection of two nonlinear systems is itself nonlinear.

Justify your answer.

- (c) Consider three systems with the following input-output relationships:

$$\text{System 1: } y[n] = \begin{cases} x[n/2], & n \text{ even} \\ 0, & n \text{ odd} \end{cases},$$

System 2: $y[n] = x[n] + \frac{1}{2}x[n-1] + \frac{1}{4}x[n-2],$

System 3: $y[n] = x[2n].$

Suppose that these systems are connected in series as depicted in Figure P1.42. Find the input-output relationship for the overall interconnected system. Is this system linear? Is it time invariant?

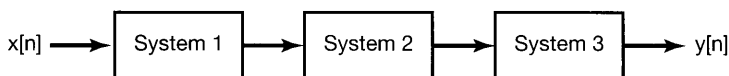

Figure P1.42

- 1.43. (a) Consider a time-invariant system with input $x(t)$ and output $y(t)$. Show that if $x(t)$ is periodic with period T , then so is $y(t)$. Show that the analogous result also holds in discrete time.
 (b) Give an example of a time-invariant system and a nonperiodic input signal $x(t)$ such that the corresponding output $y(t)$ is periodic.
- 1.44. (a) Show that causality for a continuous-time linear system is equivalent to the following statement:

For any time t_0 and any input $x(t)$ such that $x(t) = 0$ for $t < t_0$, the corresponding output $y(t)$ must also be zero for $t < t_0$.

The analogous statement can be made for a discrete-time linear system.

- (b) Find a nonlinear system that satisfies the foregoing condition but is not causal.
 (c) Find a nonlinear system that is causal but does not satisfy the condition.
 (d) Show that invertibility for a discrete-time linear system is equivalent to the following statement:
 The only input that produces $y[n] = 0$ for all n is $x[n] = 0$ for all n .
 The analogous statement is also true for a continuous-time linear system.
 (e) Find a nonlinear system that satisfies the condition of part (d) but is not invertible.
- 1.45. In Problem 1.37, we introduced the concept of correlation functions. It is often important in practice to compute the correlation function $\phi_{hx}(t)$, where $h(t)$ is a fixed given signal, but where $x(t)$ may be any of a wide variety of signals. In this case, what is done is to design a system S with input $x(t)$ and output $\phi_{hx}(t)$.
 (a) Is S linear? Is S time invariant? Is S causal? Explain your answers.
 (b) Do any of your answers to part (a) change if we take as the output $\phi_{xh}(t)$ rather than $\phi_{hx}(t)$?
- 1.46. Consider the feedback system of Figure P1.46. Assume that $y[n] = 0$ for $n < 0$.

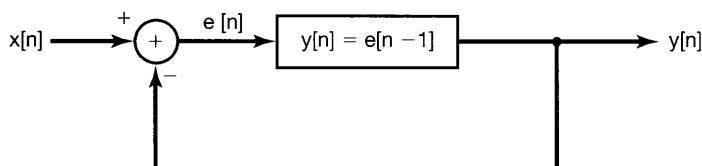

Figure P1.46

- (a) Sketch the output when $x[n] = \delta[n]$.
 (b) Sketch the output when $x[n] = u[n]$.
- 1.47. (a) Let S denote an incrementally linear system, and let $x_1[n]$ be an arbitrary input signal to S with corresponding output $y_1[n]$. Consider the system illustrated in Figure P1.47(a). Show that this system is linear and that, in fact, the overall input-output relationship between $x[n]$ and $y[n]$ does not depend on the particular choice of $x_1[n]$.
- (b) Use the result of part (a) to show that S can be represented in the form shown in Figure 1.48.
- (c) Which of the following systems are incrementally linear? Justify your answers, and if a system is incrementally linear, identify the linear system L and the zero-input response $y_0[n]$ or $y_0(t)$ for the representation of the system as shown in Figure 1.48.
- (i) $y[n] = n + x[n] + 2x[n + 4]$
- (ii) $y[n] = \begin{cases} n/2, & n \text{ even} \\ (n-1)/2 + \sum_{k=-\infty}^{(n-1)/2} x[k], & n \text{ odd} \end{cases}$

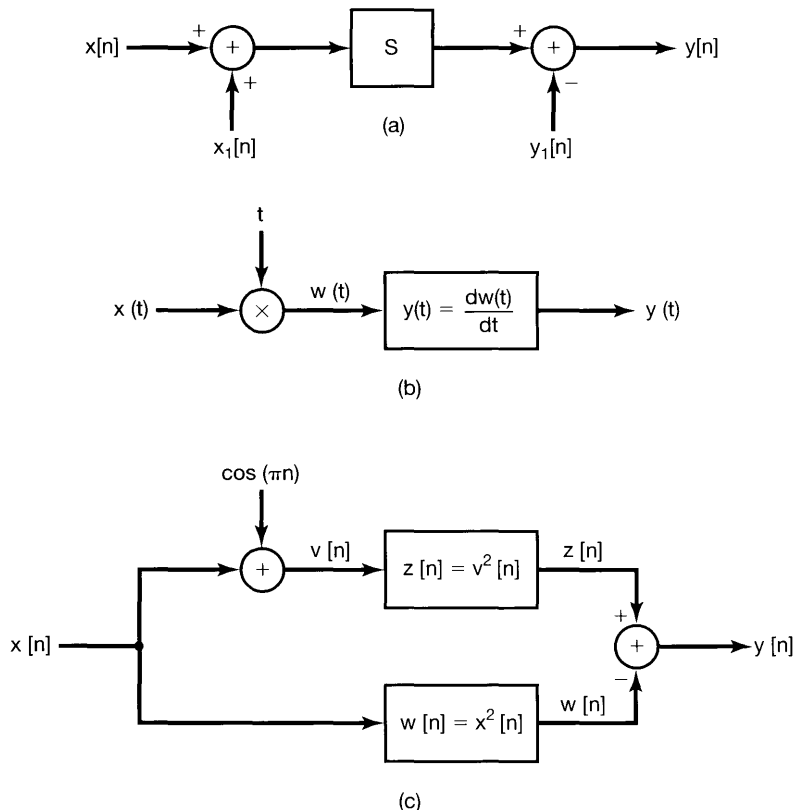

Figure P1.47

- (iii) $y[n] = \begin{cases} x[n] - x[n-1] + 3, & \text{if } x[0] \geq 0 \\ x[n] - x[n-1] - 3, & \text{if } x[0] < 0 \end{cases}$
- (iv) The system depicted in Figure P1.47(b).
- (v) The system depicted in Figure P1.47(c).
- (d) Suppose that a particular incrementally linear system has a representation as in Figure 1.48, with L denoting the linear system and $y_0[n]$ the zero-input response. Show that S is time invariant if and only if L is a time-invariant system and $y_0[n]$ is constant.

MATHEMATICAL REVIEW

The complex number z can be expressed in several ways. The *Cartesian* or *rectangular* form for z is

$$z = x + jy,$$

where $j = \sqrt{-1}$ and x and y are real numbers referred to respectively as the *real part* and the *imaginary part* of z . As we indicated earlier, we will often use the notation

$$x = \Re\{z\}, y = \Im\{z\}.$$

The complex number z can also be represented in *polar form* as

$$z = re^{j\theta},$$

where $r > 0$ is the *magnitude* of z and θ is the *angle* or *phase* of z . These quantities will often be written as

$$r = |z|, \theta = \angle z.$$

The relationship between these two representations of complex numbers can be determined either from *Euler's relation*,

$$e^{j\theta} = \cos \theta + j \sin \theta,$$

or by plotting z in the complex plane, as shown in Figure P1.48, in which the coordinate axes are $\Re\{z\}$ along the horizontal axis and $\Im\{z\}$ along the vertical axis. With respect to this graphical representation, x and y are the Cartesian coordinates of z , and r and θ are its polar coordinates.

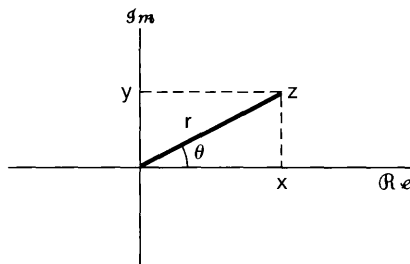

Figure P1.48

1.48. Let z_0 be a complex number with polar coordinates (r_0, θ_0) and Cartesian coordinates (x_0, y_0) . Determine expressions for the Cartesian coordinates of the following complex numbers in terms of x_0 and y_0 . Plot the points $z_0, z_1, z_2, z_3, z_4,$ and z_5 in the complex plane when $r_0 = 2$ and $\theta_0 = \pi/4$ and when $r_0 = 2$ and $\theta_0 = \pi/2$. Indicate on your plots the real and imaginary parts of each point.

$$\begin{array}{lll} \text{(a)} z_1 = r_0 e^{-j\theta_0} & \text{(b)} z_2 = r_0 & \text{(c)} z_3 = r_0 e^{j(\theta_0 + \pi)} \\ \text{(d)} z_4 = r_0 e^{j(-\theta_0 + \pi)} & \text{(e)} z_5 = r_0 e^{j(\theta_0 + 2\pi)} & \end{array}$$

1.49. Express each of the following complex numbers in polar form, and plot them in the complex plane, indicating the magnitude and angle of each number:

$$\begin{array}{lll} \text{(a)} 1 + j\sqrt{3} & \text{(b)} -5 & \text{(c)} -5 - 5j \\ \text{(d)} 3 + 4j & \text{(e)} (1 - j\sqrt{3})^3 & \text{(f)} (1 + j)^5 \\ \text{(g)} (\sqrt{3} + j^3)(1 - j) & \text{(h)} \frac{2 - j(6/\sqrt{3})}{2 + j(6/\sqrt{3})} & \text{(i)} \frac{1 + j\sqrt{3}}{\sqrt{3} + j} \\ \text{(j)} j(1 + j)e^{j\pi/6} & \text{(k)} (\sqrt{3} + j)2\sqrt{2}e^{-j\pi/4} & \text{(l)} \frac{e^{j\pi/3} - 1}{1 + j\sqrt{3}} \end{array}$$

1.50. (a) Using Euler's relationship or Figure P1.48, determine expressions for x and y in terms of r and θ .

(b) Determine expressions for r and θ in terms of x and y .

(c) If we are given only r and $\tan \theta$, can we uniquely determine x and y ? Explain your answer.

1.51. Using Euler's relation, derive the following relationships:

$$\text{(a)} \cos \theta = \frac{1}{2}(e^{j\theta} + e^{-j\theta})$$

$$\text{(b)} \sin \theta = \frac{1}{2j}(e^{j\theta} - e^{-j\theta})$$

$$\text{(c)} \cos^2 \theta = \frac{1}{2}(1 + \cos 2\theta)$$

$$\text{(d)} (\sin \theta)(\sin \phi) = \frac{1}{2} \cos(\theta - \phi) - \frac{1}{2} \cos(\theta + \phi)$$

$$\text{(e)} \sin(\theta + \phi) = \sin \theta \cos \phi + \cos \theta \sin \phi$$

1.52. Let z denote a complex variable; that is,

$$z = x + jy = re^{j\theta}.$$

The *complex conjugate* of z is

$$z^* = x - jy = re^{-j\theta}.$$

Derive each of the following relations, where $z, z_1,$ and z_2 are arbitrary complex numbers:

$$\text{(a)} zz^* = r^2$$

$$\text{(b)} \frac{z}{z^*} = e^{j2\theta}$$

$$\text{(c)} z + z^* = 2\Re\{z\}$$

$$\text{(d)} z - z^* = 2j\Im\{z\}$$

$$\text{(e)} (z_1 + z_2)^* = z_1^* + z_2^*$$

$$\text{(f)} (az_1 z_2)^* = az_1^* z_2^*, \text{ where } a \text{ is any real number}$$

$$\text{(g)} \left(\frac{z_1}{z_2}\right)^* = \frac{z_1^*}{z_2^*}$$

$$\text{(h)} \Re\left\{\frac{z_1}{z_2}\right\} = \frac{1}{2} \left[\frac{z_1 z_2^* + z_1^* z_2}{z_2 z_2^*} \right]$$

1.53. Derive the following relations, where $z, z_1,$ and z_2 are arbitrary complex numbers:

$$\text{(a)} (e^z)^* = e^{z^*}$$

$$\text{(b)} z_1 z_2^* + z_1^* z_2 = 2\Re\{z_1 z_2^*\} = 2\Re\{z_1^* z_2\}$$

- (c) $|z| = |z^*|$
 (d) $|z_1 z_2| = |z_1| |z_2|$
 (e) $\Re\{z\} \leq |z|, \Im\{z\} \leq |z|$
 (f) $|z_1 z_2^* + z_1^* z_2| \leq 2|z_1 z_2|$
 (g) $(|z_1| - |z_2|)^2 \leq |z_1 + z_2|^2 \leq (|z_1| + |z_2|)^2$

1.54. The relations considered in this problem are used on many occasions throughout the book.

- (a) Prove the validity of the following expression:

$$\sum_{n=0}^{N-1} \alpha^n = \begin{cases} N, & \alpha = 1 \\ \frac{1-\alpha^N}{1-\alpha}, & \text{for any complex number } \alpha \neq 1 \end{cases}$$

This is often referred to as the *finite sum formula*.

- (b) Show that if $|\alpha| < 1$, then

$$\sum_{n=0}^{\infty} \alpha^n = \frac{1}{1-\alpha}.$$

This is often referred to as the *infinite sum formula*.

- (c) Show also if $|\alpha| < 1$, then

$$\sum_{n=0}^{\infty} n\alpha^n = \frac{\alpha}{(1-\alpha)^2}.$$

- (d) Evaluate

$$\sum_{n=k}^{\infty} \alpha^n,$$

assuming that $|\alpha| < 1$.

1.55. Using the results from Problem 1.54, evaluate each of the following sums and express your answer in Cartesian (rectangular) form:

- (a) $\sum_{n=0}^9 e^{j\pi n/2}$ (b) $\sum_{n=-2}^7 e^{j\pi n/2}$
 (c) $\sum_{n=0}^{\infty} (\frac{1}{2})^n e^{j\pi n/2}$ (d) $\sum_{n=2}^{\infty} (\frac{1}{2})^n e^{j\pi n/2}$
 (e) $\sum_{n=0}^9 \cos(\frac{\pi}{2}n)$ (f) $\sum_{n=0}^{\infty} (\frac{1}{2})^n \cos(\frac{\pi}{2}n)$

1.56. Evaluate each of the following integrals, and express your answer in Cartesian (rectangular) form:

- (a) $\int_0^4 e^{j\pi t/2} dt$ (b) $\int_0^6 e^{j\pi t/2} dt$
 (c) $\int_2^8 e^{j\pi t/2} dt$ (d) $\int_0^{\infty} e^{-(1+j)t} dt$
 (e) $\int_0^{\infty} e^{-t} \cos(t) dt$ (f) $\int_0^{\infty} e^{-2t} \sin(3t) dt$