

Experiment 5: Frequency Modulation and Demodulation (2 weeks)

I. OBJECTIVES

Upon completion of this experiment, you should be able to:

1. Generate a frequency modulated (FM) signal.
2. Analyze an FM signal in time and frequency domains.
3. Predict the bandwidth of FM signals using Carson's rule; compare with observed.
4. Predict the spectrum of wide-band FM signals using Woodward's Rule; compare with observed.
5. Demodulate FM signals using a slope detector.
6. Demodulate FM signals using a phase-locked loop (PLL).

II. INTRODUCTION

Spectrum of an angle-modulated signal. As shown in your textbook, the one-sided spectrum of a tone modulated FM signal is:

$$S(f) = \sum_{n=-\infty}^{\infty} J_n(\beta) \delta(f - f_c - nf_m)$$

Bessel functions $J_n(\beta)$ plotted as a function of β^1 for $n = 0, 1$, and 2 are shown in Figure 1.

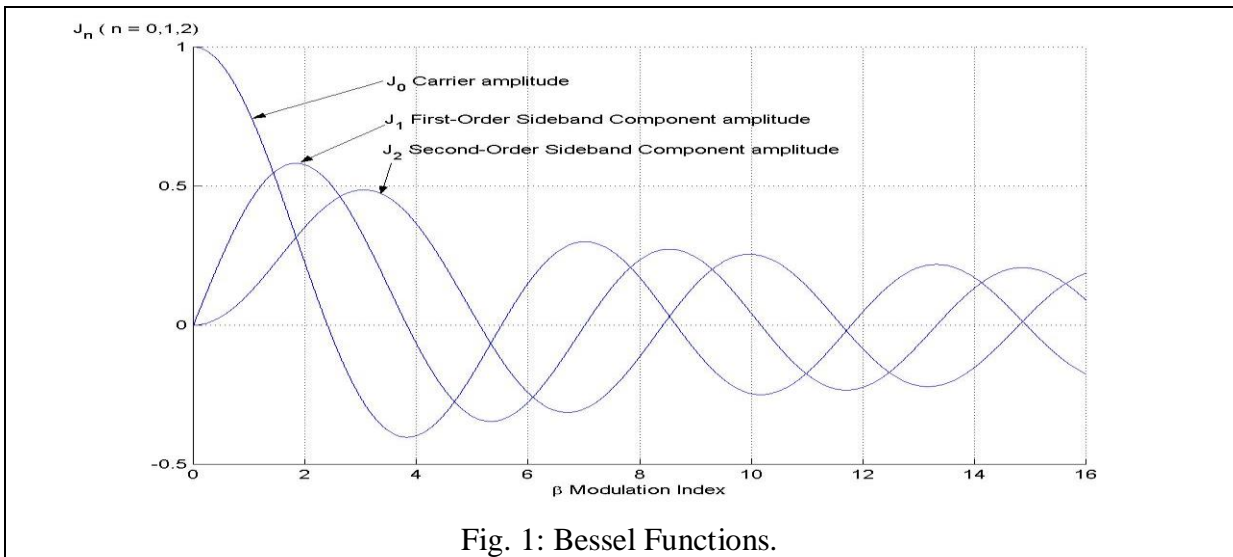

Fig. 1: Bessel Functions.

The values of the Bessel functions for negative n can be determined from:

$$J_{-n}(\beta) = (-1)^n J_n(\beta).$$

010810

¹ $\beta = \frac{\Delta f}{f_m} = \frac{f_d A_m}{f_m}$ where Δf is maximum frequency deviation of the modulated signal,

f_d is the frequency deviation constant of the modulator (Hz/V),

and f_m and A_m are the frequency and amplitude (0 to peak) of the modulating sinusoid.

Woodward's Theorem

For wide-band FM, Woodward's theorem is an approximation for the power spectral density of the modulated signal, $G(f)$, in terms of the probability density function, $p_m(x)$, of the modulating signal:

$$G(f) = \frac{A_c^2}{2f_d} \left(p_m \left(\frac{f - f_c}{f_d} \right) + p_m \left(\frac{-f - f_c}{f_d} \right) \right)$$

f_c : Carrier Frequency

f_d : Frequency Deviation Constant (Hz/V)

A_c : Carrier Amplitude

For wideband FM, Woodward's Theorem states that the magnitude of power spectrum of the FM signal is proportional to the percentage of time the message spends at a particular voltage level. Sine, square, and triangle wave modulating signals will be used to investigate $G(f)$.

III. PRELAB

1. Write a general expression for an angle modulated signal. What is the general form for the spectrum of a frequency-modulated signal if the message signal is given by:

$$m(t) = A_m \cos(2\pi f_m t) ?$$

2. What is the correct terminology for β for FM systems?
What does β represent? What are the units of β ?
3. Is angle modulation a linear process? Why or why not?
4. Is demodulation of an angle-modulated signal a linear process? Why or why not?
5. The output frequency of the HP3314A's voltage controlled oscillator (VCO) is nearly a linear function of its input voltage. Why does it need to be linear?

The slope of this curve is the *frequency deviation constant*:

$$f_d = \frac{df_{out}}{dV_{in}} \approx \frac{\Delta f_{out}}{\Delta V_{in}} .$$

6. If a test-set VCO has $f_d = 100,000$ hertz/volt at a center frequency of 100 MHz, what are the highest and lowest output frequencies if the input is:

$$m(t) = \cos(2\pi 1000 t) ?$$

7. Draw a block diagram of phase-lock loop. (Refer to [1] if necessary).
When the input is an FM signal what does the error voltage of the PLL correspond to?

IV. EXPERIMENT

1. VCO Characteristics.

A voltage controlled oscillator, VCO, is a simple way of generating an FM signal. The voltage-to-frequency characteristic of the VCO should be linear over the range of operation. The slope of this curve is the frequency deviation constant:

$$f_d = \frac{df_{out}}{dV_{in}} = \frac{\Delta f_{out}}{\Delta V_{in}}.$$

- 1 a. Connect a dc voltage source to the HP3314A VCO input and observe the frequency deviation from a nominal center frequency of 300 kHz. Take 10 data points for dc voltages between -1 to +1 volts. Measure the input voltage with a DMM and the output frequency with a frequency counter. Plot the frequency deviation vs. the input voltage.
- 1 b. Is the voltage-to-frequency characteristic linear? Determine f_d .

2. FM Spectra for a sinusoidal message.

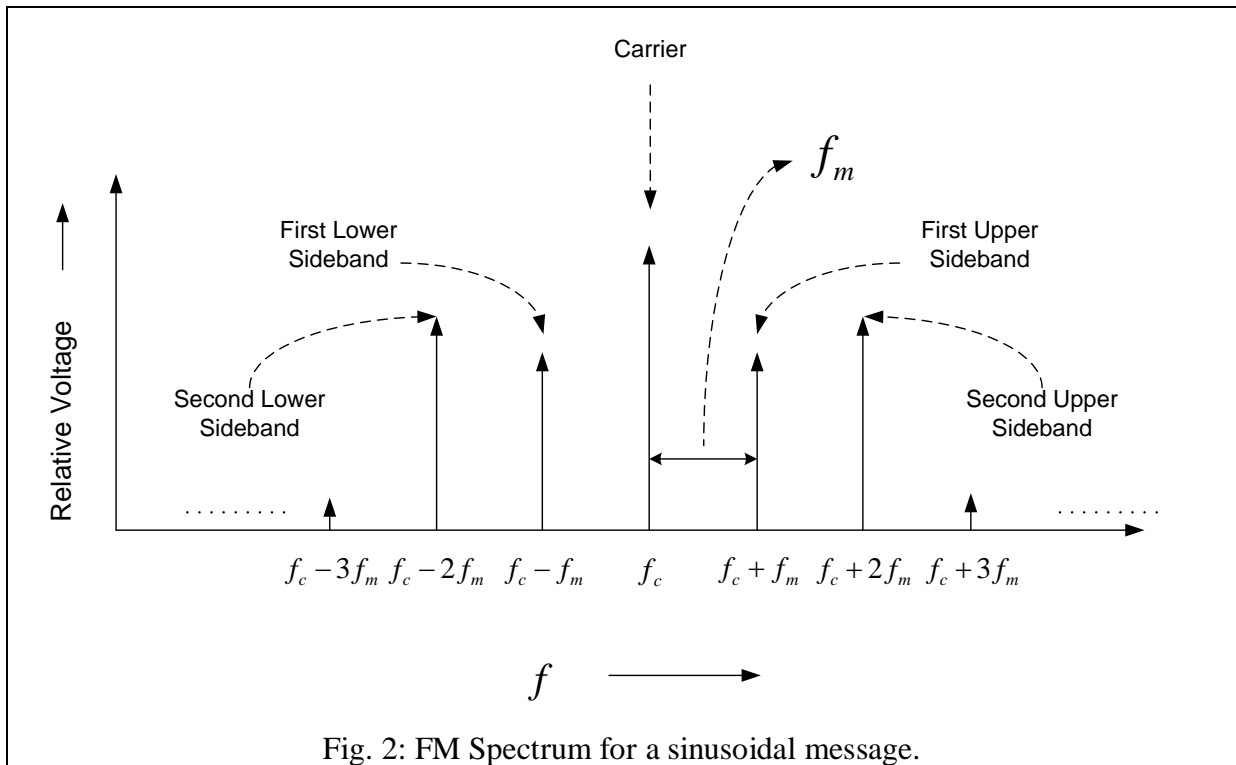

- 2 a. Generate an FM signal using the HP3314A (carrier frequency at 300 kHz) with a modulating sinusoid amplitude less than 2 V_{pk-pk}. Observe the spectrum of the FM signal. Note that the spectrum changes as you vary β . You can vary β by changing either the frequency or amplitude of the modulating signal or both; find a suitable fixed frequency and adjust the amplitude (less than 2 V_{pk-pk}).

2. FM Spectra for a sinusoidal message. (continued)

2 b. Obtain and record data to plot:

Normalized amplitudes for the carrier, 1st sideband, and 2nd sideband vs. β .

Take enough data for three zeroes of the carrier, two zeroes of the first sideband, and one zero of the second sideband.

The value of β can be obtained from the estimate of f_d and Equation 3.87 of [1].

The curves should look like the Bessel functions of Figure.1.

Do the first two zeroes of the carrier amplitude occur at $\beta = 2.4$ and 5.57 ?

3. Carson's Rule and Woodward's Theorem

Use a 250 Hz sine wave, square wave, and triangle wave to frequency modulate the HP3314A. Choose the amplitude of the message such that the maximum frequency deviation is 30 kHz.

3 a. Observe the modulated signals on the spectrum analyzer and estimate their bandwidths and compare to the bandwidth estimated using Carson's Rule.

3 b. Make sketches (or obtain print-outs) of the spectra and compare to predictions of Woodward's Theorem.

4. FM Demodulation Using Slope Detection.

Slope Detection² converts the FM signal to an amplitude modulated AM-FM signal using the slope of a filter circuit. Since the peak-to-peak amplitude of the FM signal is constant, on the up-slope of a band-pass filter circuit a lower frequency will yield a lower voltage, a higher frequency will yield a higher voltage. When the output of the filter is envelope detected, the original message is recovered. Figure 3 shows a block diagram of a slope detector system.

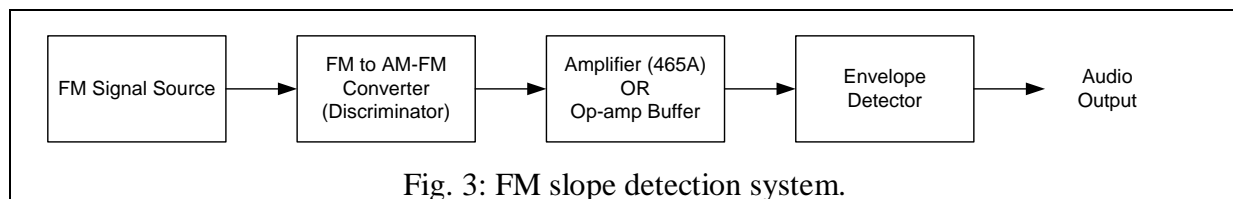

Fig. 3: FM slope detection system.

The band-pass filter shown in Figure 4 may be used to demodulate FM. Adjust the value of R to provide a large linear region in the frequency response. A display of the frequency response may be obtained **exactly** as the network analyzer display built in Experiment 2. Choose the center frequency of your FM signal to be in the center of the linear region, and the bandwidth chosen to keep the spectrum in the linear region. You may use the envelope detector available in the TIMS utilities plug-in card; however, its bandwidth is rather low.

4 a. Sketch or printout the magnitude frequency response of your circuit. Compare with the predicted bandwidth. Indicate the useful “linear” region for demodulation.

4 b. Record the carrier frequency and maximum deviation you chose.

4 c. Modulate a music message and observe the quality of the audio output.

² Discriminators are tuned circuits crafted to form an $H(f)$ with a flat rising slope. The slope demodulates FM radio signals. Signals with frequencies on the slope are “differentiated” because a flat rising slope has a transfer function $H(j\omega) \approx K_1 * j\omega + K_2$. Since K_2 is constant the input signal is differentiated (multiplied by $j\omega$).

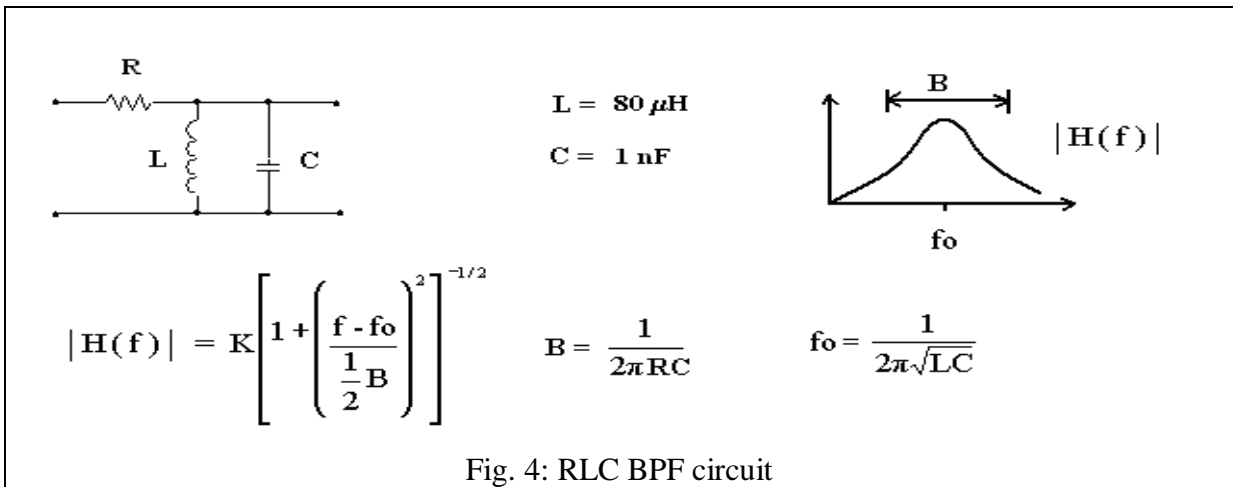

5. Phase-Locked Loops

A Signetics NE565 phase-locked loop is used in the system shown in Figure 5. This system will demonstrate some basic properties of phase-locked loops and demodulate FM signals.

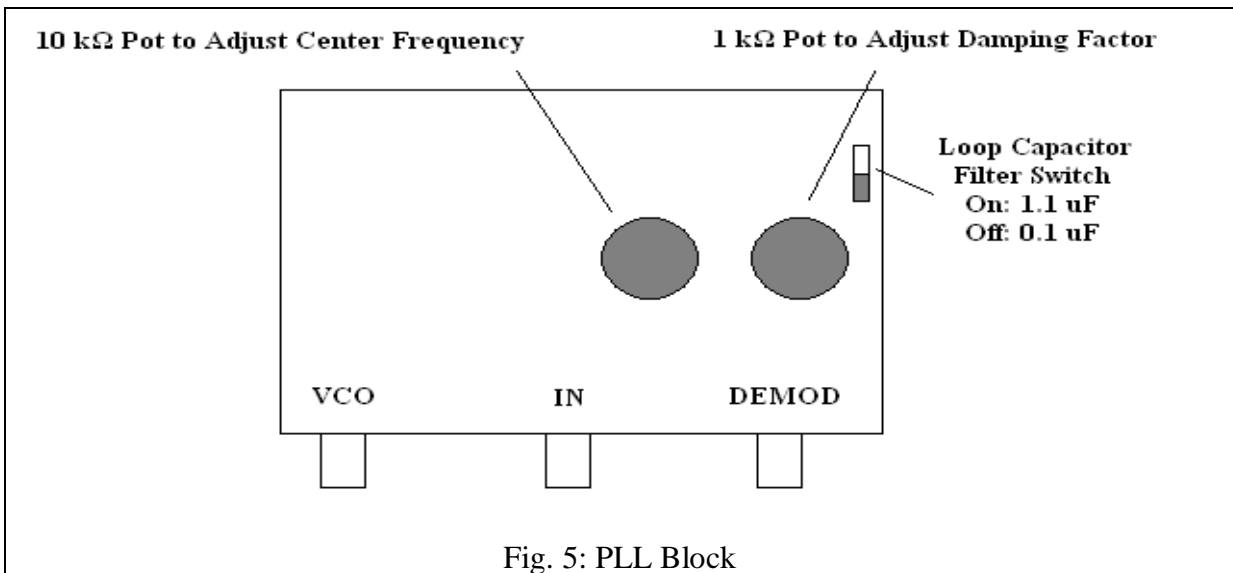

- 5 a. Set the free running (or center) frequency. Adjust the 10 kΩ pot so that the VCO square wave frequency of the PLL is exactly 100 kHz.
- 5 b. Connect a **100 kHz 200 mV_{p-p}** sine wave from a **HP3314A** to the PLL input <IN>. The PLL should now lock to this frequency. Detect lock by observing the PLL <IN> input and the <VCO> output on a scope. (Trigger on <IN>.) Lock is indicated by the VCO output appearing to stay still. If it jitters or moves, the PLL is unlocked.
- 5 c. Lock and Capture Ranges of the PLL.

The lock range³ is the range of frequencies over which the loop will remain in lock. The capture range is the range of frequencies over which the loop can acquire lock.

Determine the lock and capture ranges of the PLL by varying the 3314A frequency.

³ The lock range is also called the tracking range or hold-in range. Theoretically, the lock range is $f_0 \pm K_f$, where K_f is the total effective loop gain of the PLL. The capture range is dependent on both the loop gain and the loop filter.

6. **FM demodulation using PLL.**

6a. **Set the input signal.**

Use a 100 Hz square wave to frequency-modulate the HP3314A VCO. Adjust the amplitude of the square wave to obtain a peak frequency deviation of 1 kHz. Connect the signal to the input connector on the PLL, <IN>.

6 b. **Set the measurement set-up.**

Connect the demodulated output of the PLL (BNC jack marked <DEMOD>) to the oscilloscope input using a BNC to BNC cable. As shown in Figure 7, the oscilloscope trace will show lots of residual demodulation noise. Ask your TA to show you how to apply the “Average 1” setting on the oscilloscope to filter the noise in the display.

7. **Using the PLL as a Linear System to demodulate the FM signal.**

The PLL circuit is a second order loop. The parameters associated with a second order system are the natural frequency f_n , and the damping factor ζ . The *natural frequency* is the free running (or center) frequency of 5a and Figure 5, above. (EE382 discusses these in detail.) Equations for these parameters (from the data sheet for the National Semiconductor, LM565CN Phase Lock Loop) are given below:

$$f_n = \frac{1}{2\pi} \sqrt{\frac{K_1}{(\tau_1 + \tau_2)}} \quad \text{and} \quad \zeta \approx \frac{\tau_2}{2} \sqrt{\frac{K_1}{(\tau_1 + \tau_2)}}$$

$$\tau_1 = R_1 \times C \quad \text{and} \quad \tau_2 = R_2 \times C$$

Here K_1 is the loop gain in Hz and τ_1 and τ_2 are loop filter time constants.

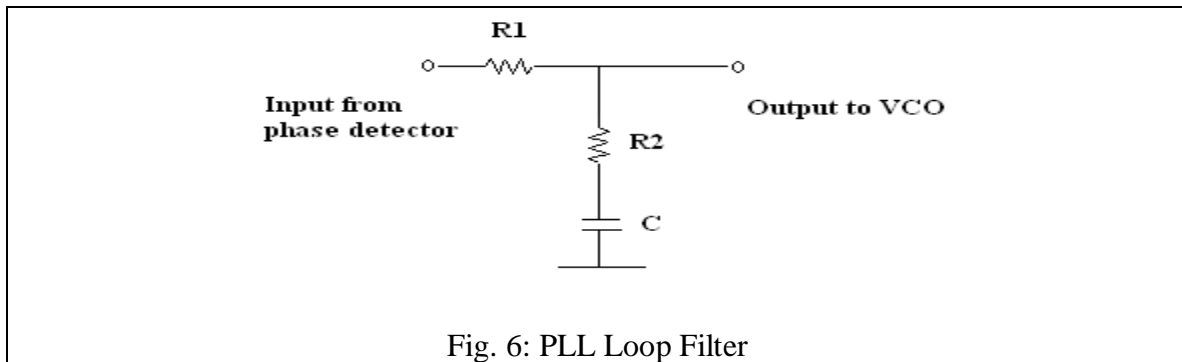

7 a. The damping factor ζ can be adjusted by the 1 k Ω pot, (R2), shown in Figure 5.

Adjust R2 to observe the effects of changing the damping factor

You should see waveforms similar to those shown in Figure 7a, b, c, and d,

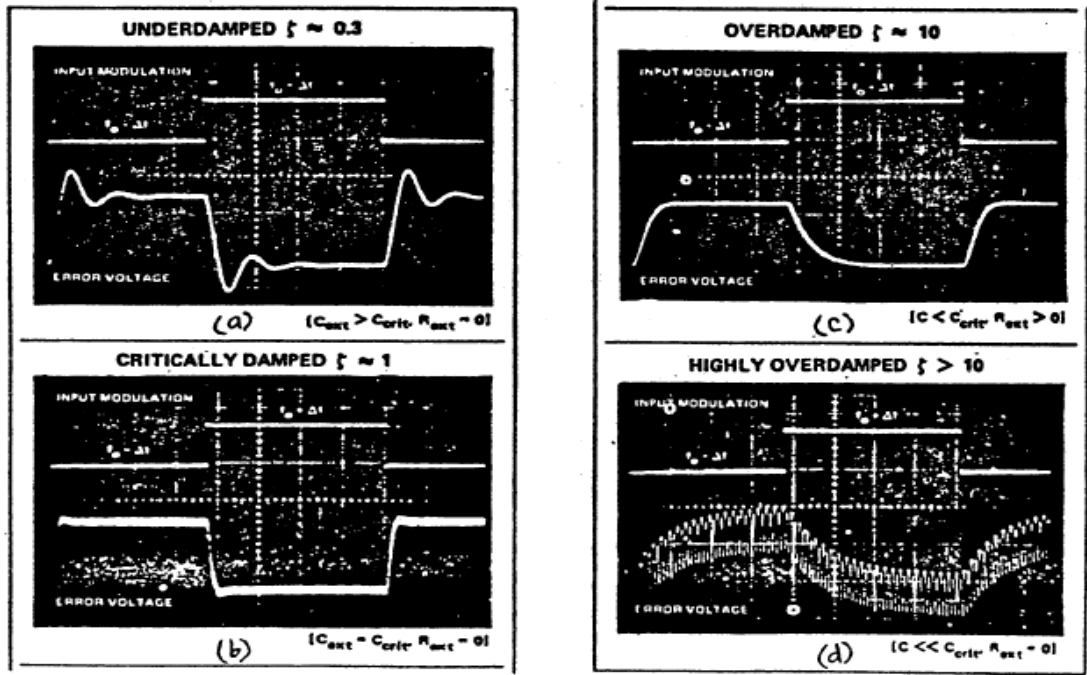

Fig. 7: Loop Step Responses

- 7 b. Adjust the 1 kΩ pot for $\zeta \approx 0.3$ as indicated by a display similar to Figure 7(a). Change the modulating signal to a sine wave; adjust its amplitude to obtain a peak frequency deviation of 500 Hz. Vary the frequency of the modulating sine wave to observe a frequency response (demodulated output) similar to that shown in Figure 8.

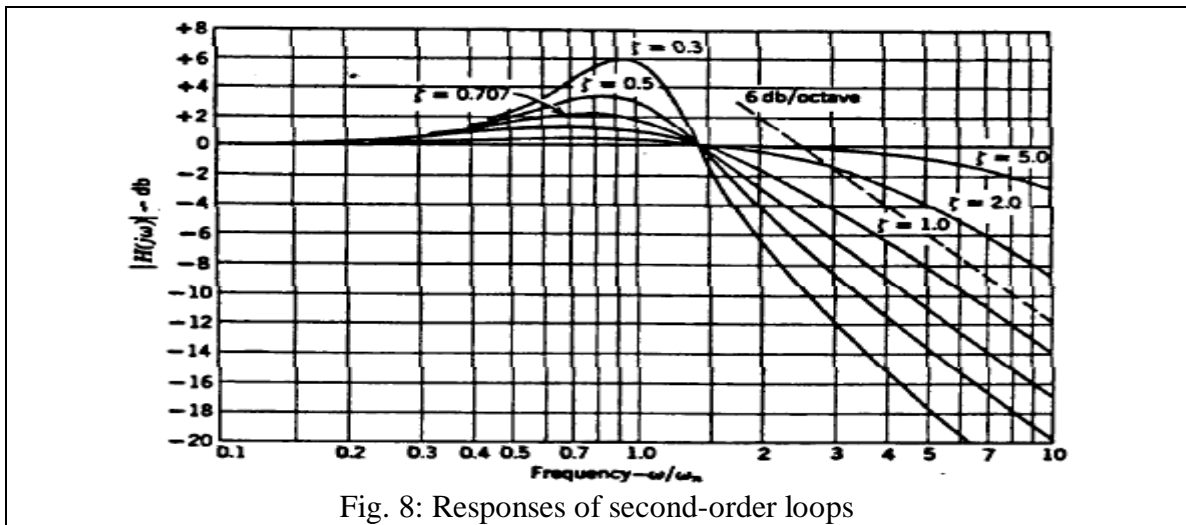

Fig. 8: Responses of second-order loops

8. Causing Non Linear Operation of the Phase Lock Loop.

The PLL is inherently non-linear (the phase-detector is non-linear.) It can be approximated as a linear system if the phase variation of the input signal is small and this is what was done in the previous section. In this section, large phase variations are applied to the input signal to observe the non-linear behavior of the PLL.

- 8 a. Ensure that ζ is set to approximately 0.3. Use a 100 Hz square wave as the message signal to the 3314A VCO. Increase the level of the modulating square wave until you observe a waveform similar to that shown in Figure 9. At this point the PLL is losing lock and then regaining it (a non-linear phenomenon). Adjust ζ to vary the mean time-to-lock of the PLL. Note the difference between Figure 7(a) and Figure 9 very carefully; one is a linear phenomenon and the other is non-linear.

Obtain a plot of the capture process showing the error beat-frequency transient.

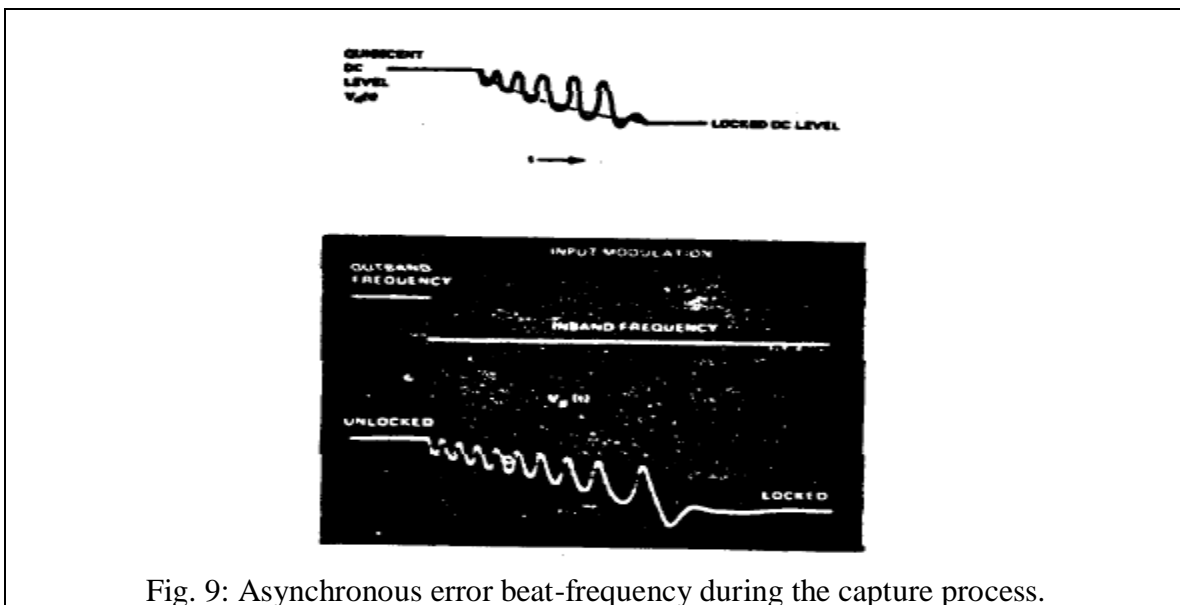

Fig. 9: Asynchronous error beat-frequency during the capture process.

- 8 b. Next, use music from a CD player as a modulating signal. Also, change the loop filter capacitor to 0.1 μF . Listen to the demodulated output. You should be able to hear the effect of changing ζ on the loop frequency response.

IV. REPORT

Document all the readings you have obtained and any conclusions you draw in your report. Attach a copy of your lab record to the report. Answer any specific questions asked in the lab manual.

REFERENCES

- [1] R. E. Ziemer and W. H. Tranter, *Principles of Communications*, 5th ed. Hoboken, NJ: John Wiley, 2002.